

ES

Este producto se suministra con tacos universales de alta calidad, no específicos para anclaje en paredes de yeso laminado (sin alicatar). Es responsabilidad del instalador utilizar el taco más adecuado al tipo de pared en la cual se va a colocar.

EN

This product is provided with universal high quality plastic expansion anchors. They are not specific for dry walls (without tiles). The installation engineer is responsible for using the most adequate expansion anchors for the type of wall where it is going to be installed.

FR

Ce produit est fourni avec des chevilles universelles de haute qualité, elle ne sont pas appropriées pour des murs en placoplâtre (sans carrelage). L'installateur est responsable d'utiliser la cheville la plus adéquate au type de mur où il va installer l'article.

PT

Este produto é fornecido com buchas universais de alta qualidade, não específicos para encaixe nas paredes de gesso cartonado (sem azulejo). É responsabilidade do instalador utilizar as buchas mais adequadas ao tipo de parede em que vão ser colocadas.

IT

Questo prodotto è fornito con un tassello a muro di alta qualità, non idoneo per il fissaggio diretto su pareti di cartongesso (prive di piastrelle). È responsabilità dell'installatore verificare l'idoneità della parete dove deve essere collocato.

DE

Dieses Produkt wird mit hochwertigem universellem Dübel angeboten. Nicht für die Montage an Gipswänden (ohne Fliesen) geeignet. Es liegt in der Verantwortung des Installateurs, entsprechend der Wandbeschaffenheit, den zutreffenden Dübel zu benutzen.

NL

Dit artikel wordt geleverd met universele pluggen van de beste kwaliteit, deze zijn niet geschikt voor gebruik in gipsplaten wanden (zonder tegels). De installateur is verantwoordelijk voor het gebruik van de meest geschikte plug voor de wand of muur waar hij het artikel zal plaatsen.

COSMIC

INDUSTRIAS COSMIC, S.A.U.

CERDANYA, 2
POL. IND. LA BORDA
P.O. BOX 184

08140 CALDES DE MONTBUI BARCELONA

CENTRAL OFFICE TEL +34 938 654 277 FAX +34 938 654 264

SPAIN TEL 938 664 100 FAX 938 654 264

INTERNATIONAL PHONE TEL +34 938 664 101 FAX +34 938 654 264

BELGIUM TEL 0800 111 90 FAX 0800 113 44

FRANCE TEL 0800 915 047 FAX 0800 915 048

GERMANY TEL 0800 181 7824 FAX 0800 180 1548

NETHERLANDS TEL 0800 022 0654 FAX 0800 022 0282

PORTUGAL TEL 808 201 454 FAX +34 938 654 264

info@icosmic.com
www.icosmic.com

61310-V2

THE GRID

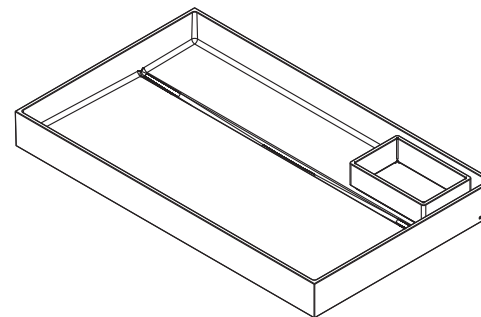

768121002
768121402
768121802

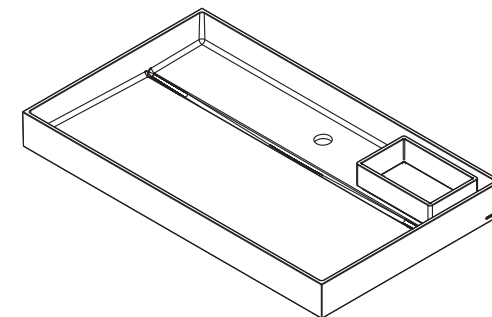

768121003
768121403
768121803

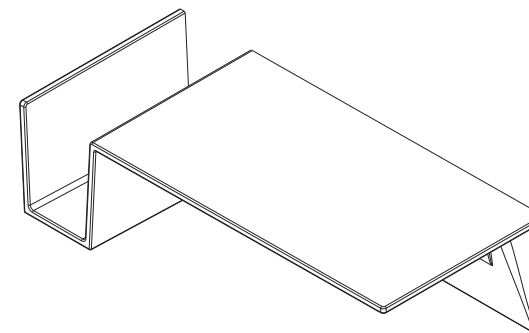

768121120

COSMIC

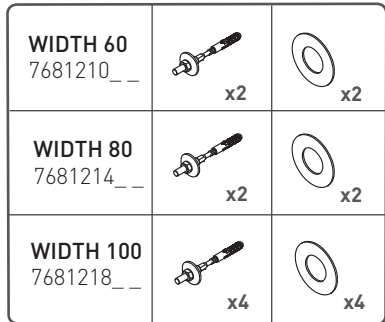
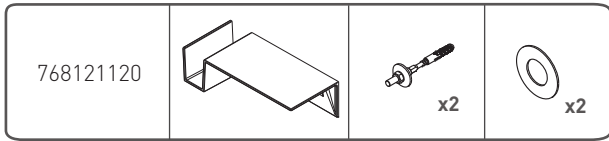
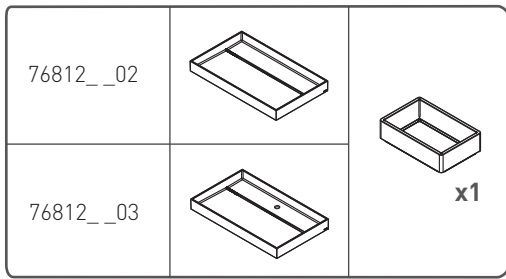

A Desagüe
Vidage
Waste pipe
Abwasserleitung
Scarico
Deságue

B Conexión agua
Connection d'eau
Water connection
Wasseranschlüsse
Carico dell'acqua
Conexão água

C Taladros fijación pared
Trous fixation mur
Wall fixation holes
Wandbefestigungslöcher
Fori de fissaggio
Brocas fixação parede!

ASSEMBLY DIMENSIONS

	600 (23-5/8")	800 (31-1/2")	1000 (39-3/8")
X	600 (23-5/8")	800 (31-1/2")	1000 (39-3/8")
Y	200 (7-7/8")	400 (15-3/4")	600 (23-5/8")
Z			200 (7-7/8")

