

MANUTENZIONE

Per la normale pulizia si consiglia di utilizzare detersivi di uso comune. Si sconsiglia l'utilizzo di detersivi abrasivi, acidi e anticalcare.

Nota

La vasca "CARTESIO" deve essere installata su un pavimento perfettamente in piano e non può essere incassata. Predisporre l'impianto di scarico a pavimento con tubo terminale diametro 40 mm con guarnizione di tenuta.

MAINTENANCE

For normal cleaning use common detergents. Do not use either abrasive detergents or solvents, acids and anti limestone.

Note

The "CARTESIO" bathtub must be positioned on a flat floor surface and cannot be built-in. Prepare the sewage mains in the floor, ending with a 40 mm diameter pipe with a sealed gasket.

Agape srl

via A. Pitentino, 6 46037 Governolo
Roncoferraro (MN), Italy

T +39 0376 250311 / F +39 0376 250330

e-mail: info@agapedesign.it

www.agapedesign.it

CONTENUTO DELLA CONFEZIONE
PACKAGE CONTENTS

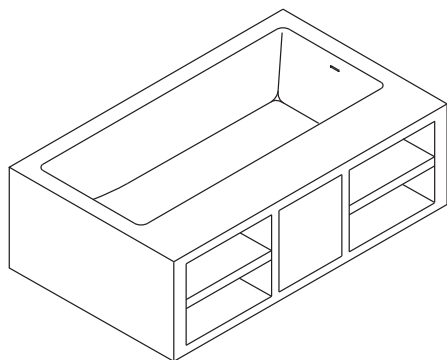

Versione con vano portaoggetti a destra.
Bathtub with storage compartments on the right.

STRUMENTI
TOOLS



trasparente - antimuffa
transparent - antimould

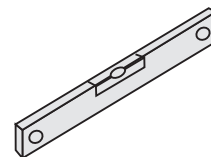

PREDISPOSIZIONE
WASHBASIN PREDISPOSITION

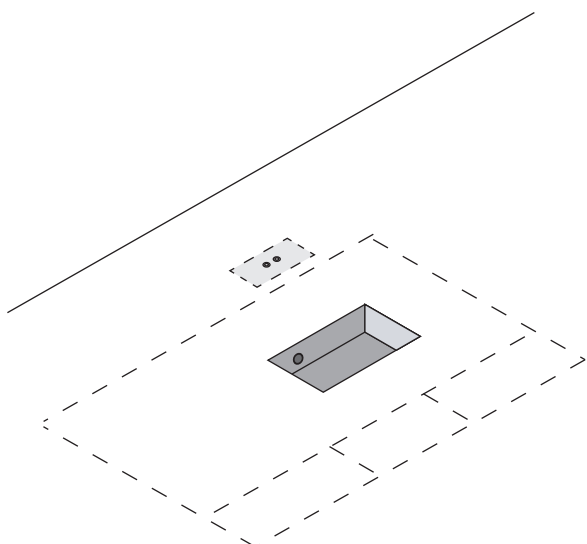
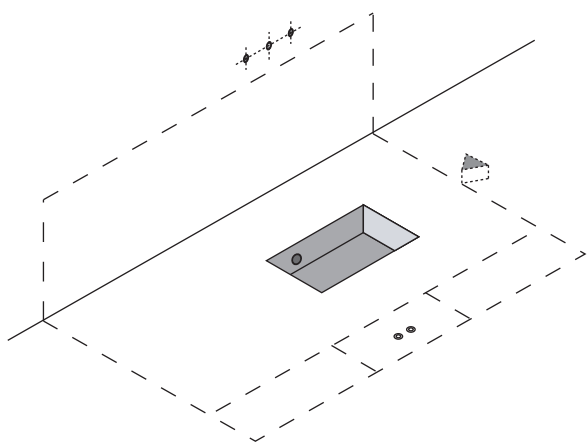

VASCA INSTALLATA
BATHTUB MOUNTED

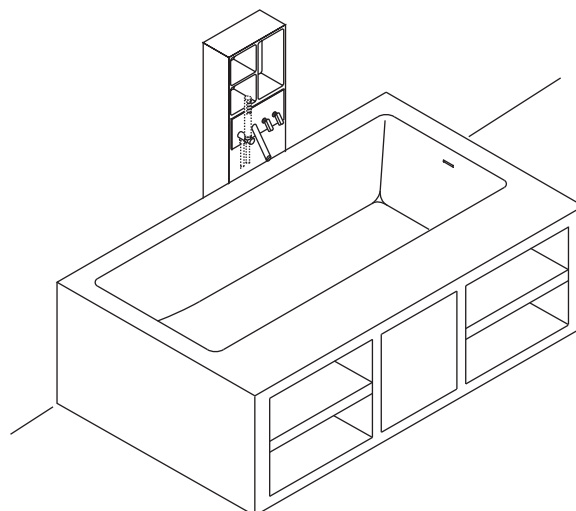
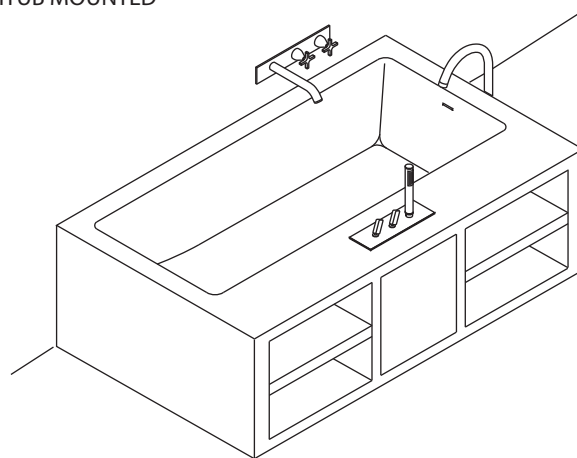

1

INSTALLAZIONE / INSTALLATION

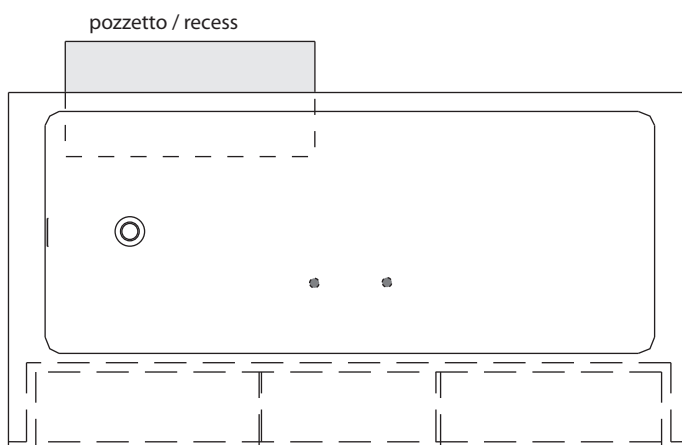

Versione con vano portaoggetti a sinistra
Bathub with storage compartments on the left

2

Posizionare i distanziatori in legno sotto alla vasca
Position the wooden spacers placed under the bathtub

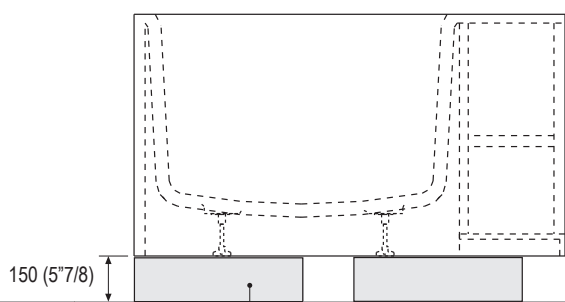

distanziatori in legno
wooden spacers

3

Collegare il sifone, la piletta e il troppo pieno
Regolare i piedini
Connect the drain trap, the waste and the overflow
Adjust the feet

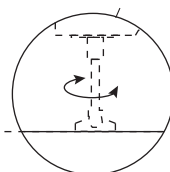
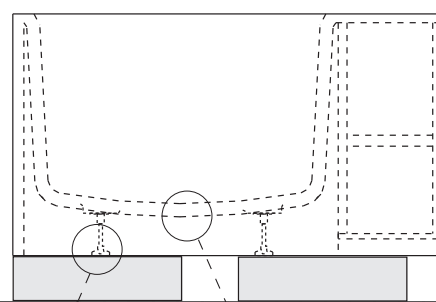

filo vasca
bathtub limit

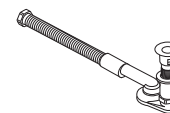

.MET0477

3

PARTICOLARE PILETTA / WASTE DETAIL

Consultare le istruzioni dedicate allo scarico
Examine the instruction dedicated of the waste

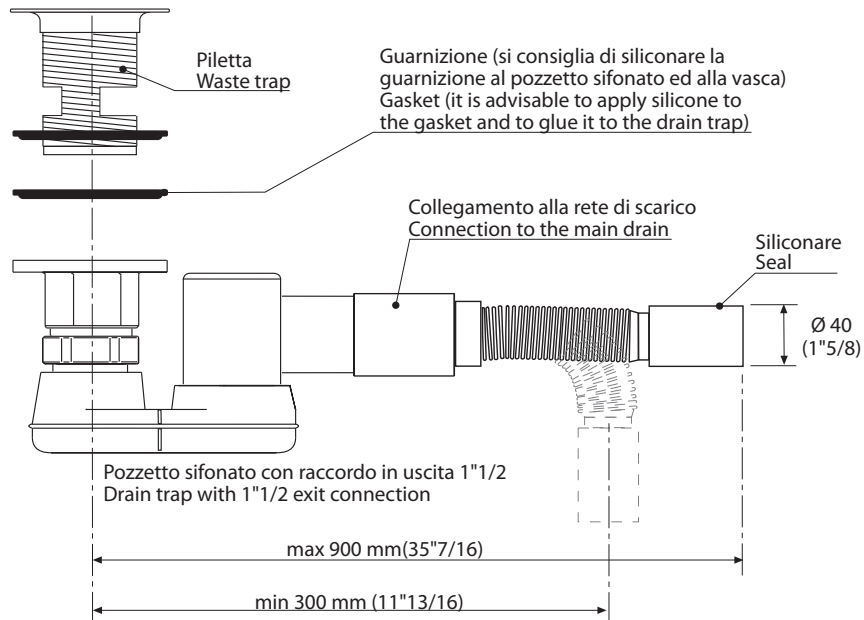

4

**INSTALLAZIONE RUBINETTERIA SQUARE (SE PRESENTE)
TAP SQUARE INSTALLATION**

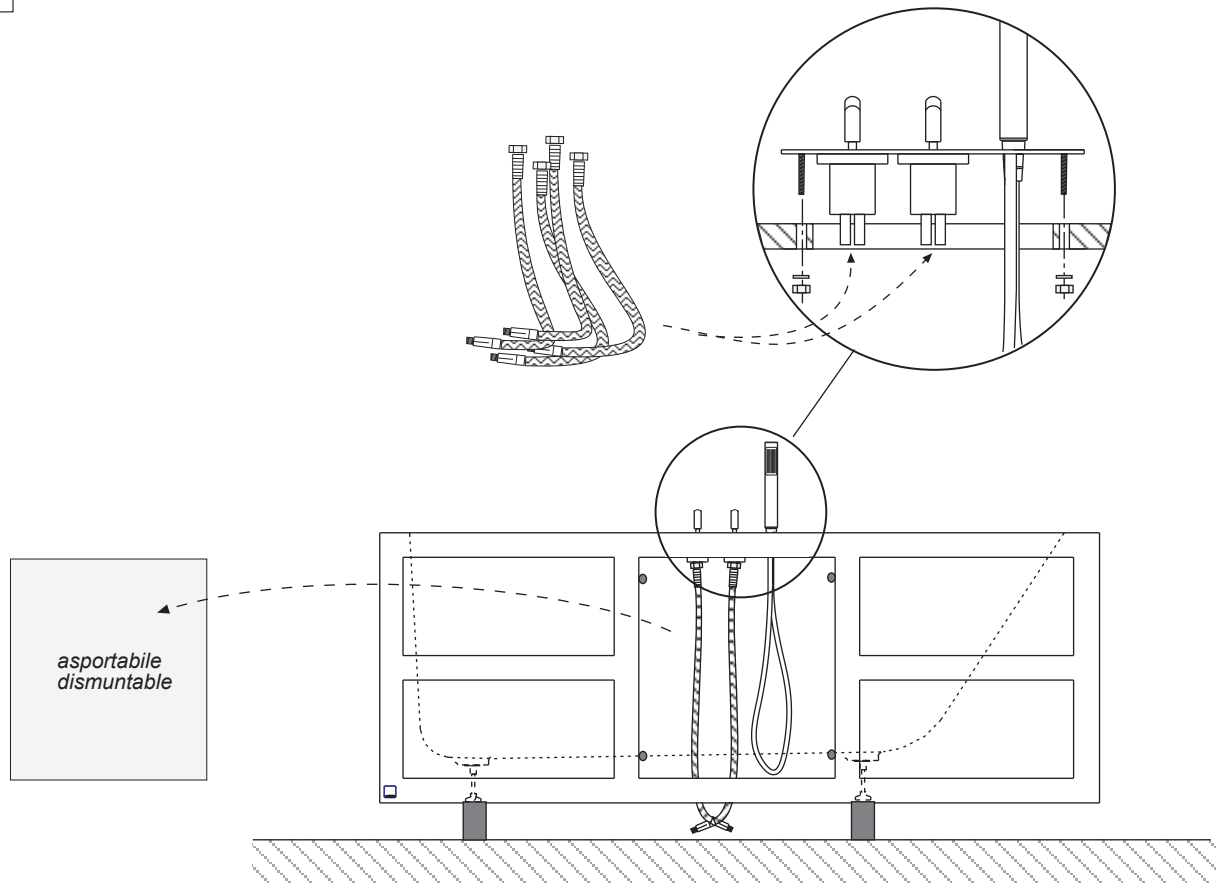

5

INSTALLAZIONE BOCCA DI EROGAZIONE (SE PRESENTE)
SPOUT INSTALLATION

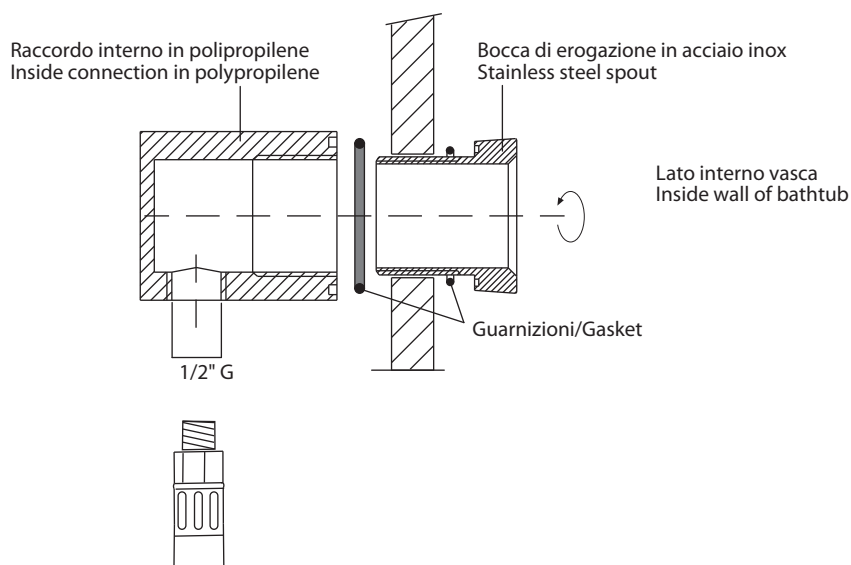

6

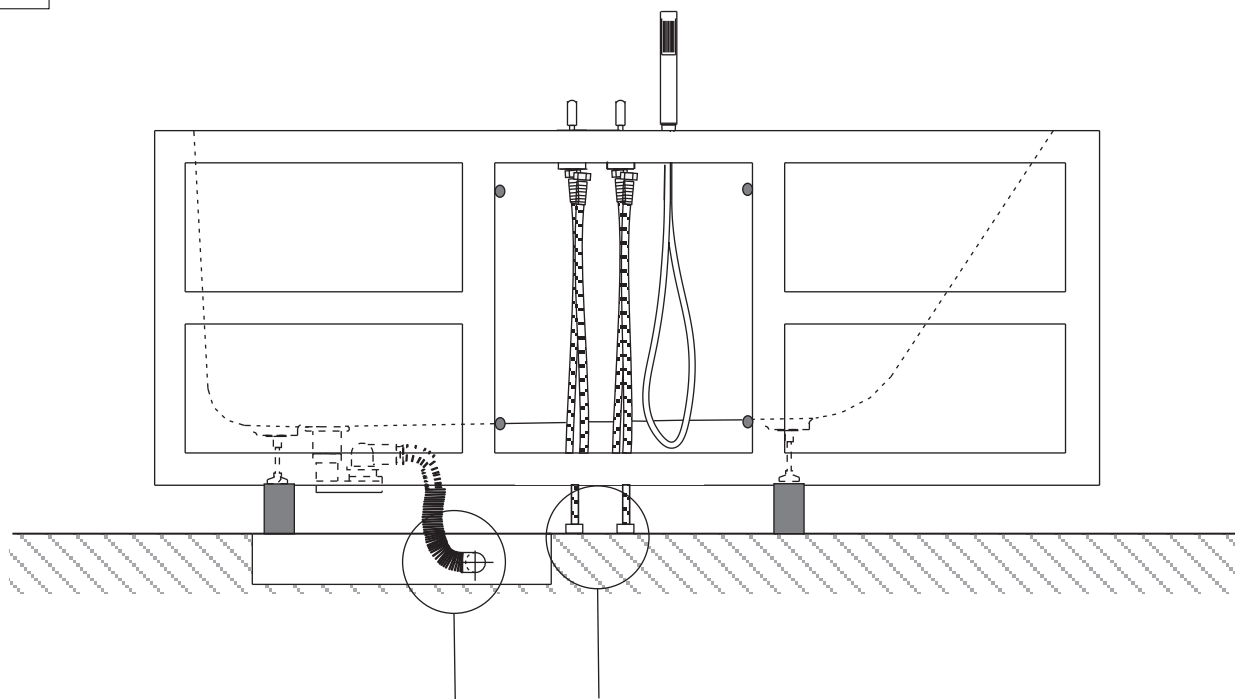

Collegare lo scarico e l'adduzioni.
Connect the flexible pipe and the feed
Effettuare alcune prove di tenuta dell'impianto realizzato.
Test different times the seal of the realised plant.

7

Nel caso non si siano verificate perdite togliere i distanziatori in legno avendo cura di non effettuare movimenti bruschi o spostamenti troppo ampi.
If no losses are occurred, remove the wooden spacers without provoking hard movements or wide shifts.

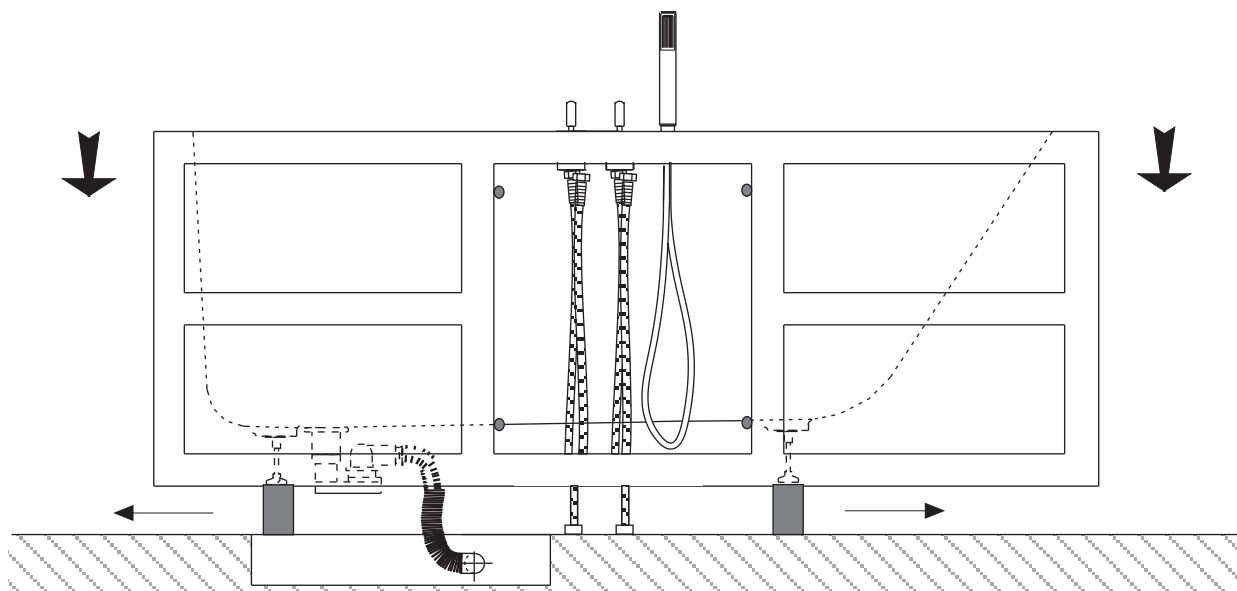

8

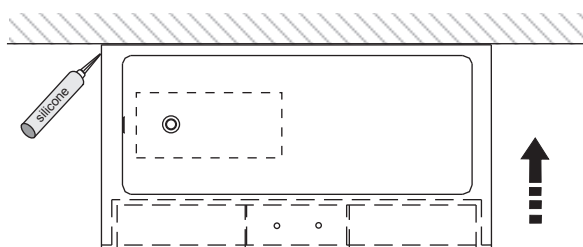

Procedere con la siliconatura perimetrale del basamento.
Apply silicone to the base perimeter.

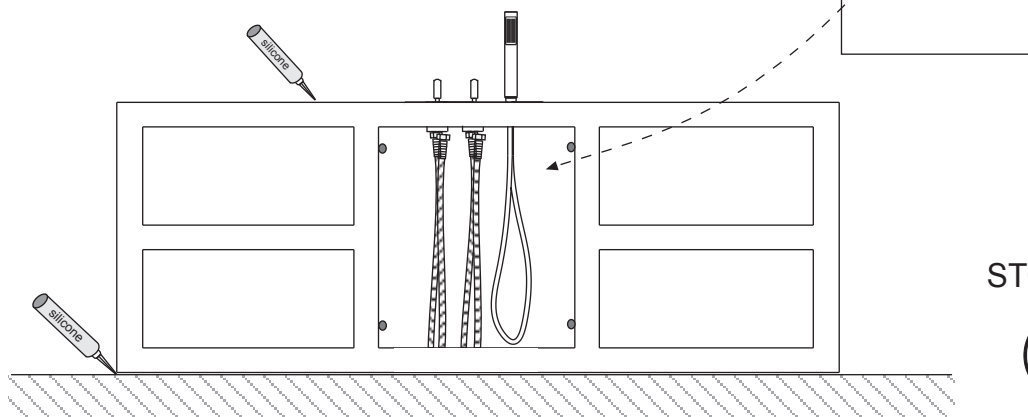

STOP 24 h.

